

# HBG2 UFO HighBay Light

## FEATURE



Brand Driver options:



Surge Protection: 6KV  
Multi-Voltage: 100-277Vac  
Dimming: 0-10V

Brand LED Chips:  LUMILEDS

High Luminous Efficacy :  
160lm/w

## Excellent Structure Design



Special hollow-out design for efficient heat dissipation. Heat of the PCB will not transfer to driver directly. Lower working temperature, the driver can be more stable.

## Parameter

MODLE NO.	HB-150-100-80G 40K90
Wattage	80W-100W-150W Switchable
Lumens(160lm /w)	From 12800lm to 24000lm
In Standard	Black Finish 30m/1 AC Cable
LEDs Type	SMD2835
CCT	4000K
CRI	80+
Beam Angle	90°
Input Voltage	100-277Vac 50-60Hz
Dimming	0-10V Dim
Power Factor	>0.95
IP Rating	IP65 /Wet Location
Working Temp.	-40°C ~ 50°C (-40°F~122°F)
Storage Temp.	-40°C ~ 70°C (-40°F~158°F)
Finish	Black (White, Gary customized)
Housing	Die-casting Aluminum
Diffuser	PC Lens
Installation	Hanging, Mounting
Lifespan(>70)	>100,000 Hours
Certification	CE, CB, Rohs, SAA
Warranty	5 Years
Diameter	Φ280mm
Height	178mm
Gross Weight	3.5KG

## Dimension

150W/100W/80W  
Switchable

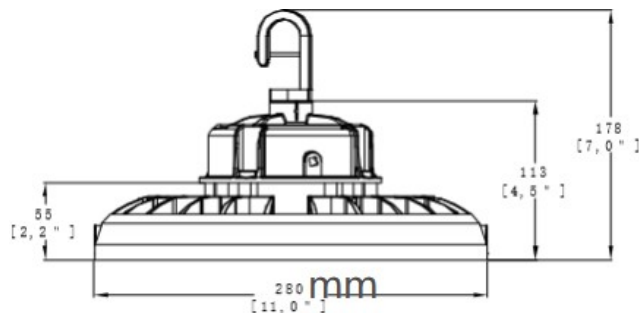

## Package Information

ITEM	QTY/CTN	G. W.	CTN SIZE
HB-150-100-80G	1pcs	3.5KG	32X32X16cm

## Photometric

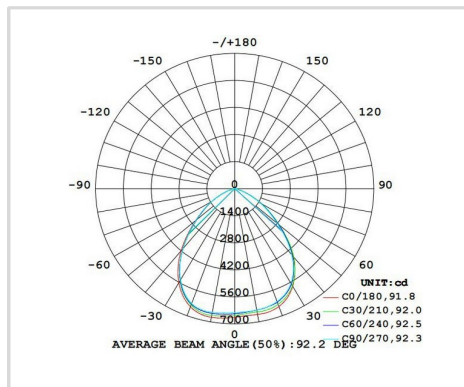

90°

## Certification

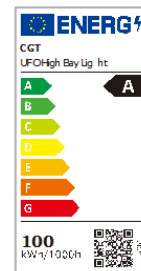

## Accessories options

Accessories options

Mount Bracket      Wire Guard      Sensor cover      Aluminum reflector      PC reflector      Drop Lens