

Wire mesh trays

can be combined with other sub-systems - a system with many common accessories.

Wire mesh trays are easy to shape and an excellent complement to e.g. the cable ladder.

Use our cable ladders for the main installation and divide/branch with wire mesh trays.

Wire mesh trays with accessories can on request be supplied in any colour.

Equipotential bonding

SP Technical Research Institute of Sweden in Borås has made test measurements equivalent to SS-EN 61537:2007.

All MP-wire mesh trays can handle demands **without screws** – see page 8.

Selection of surface finish

Equipotential bonding

Cable ladders

Cable trays/
luminaire rails

Wire mesh trays

Assembly profiles

Anchor rails

Angle profiles

MP-19" rack

Potential connections

Cable clamps

Ceiling brackets/
concrete screws

Service poles/posts

Floor boxes

Trunking systems

E-no, weight, package

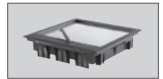
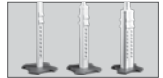
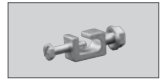
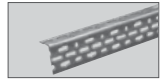
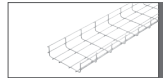

Wire mesh trays

Wire mesh trays

Numbers denote page. number.

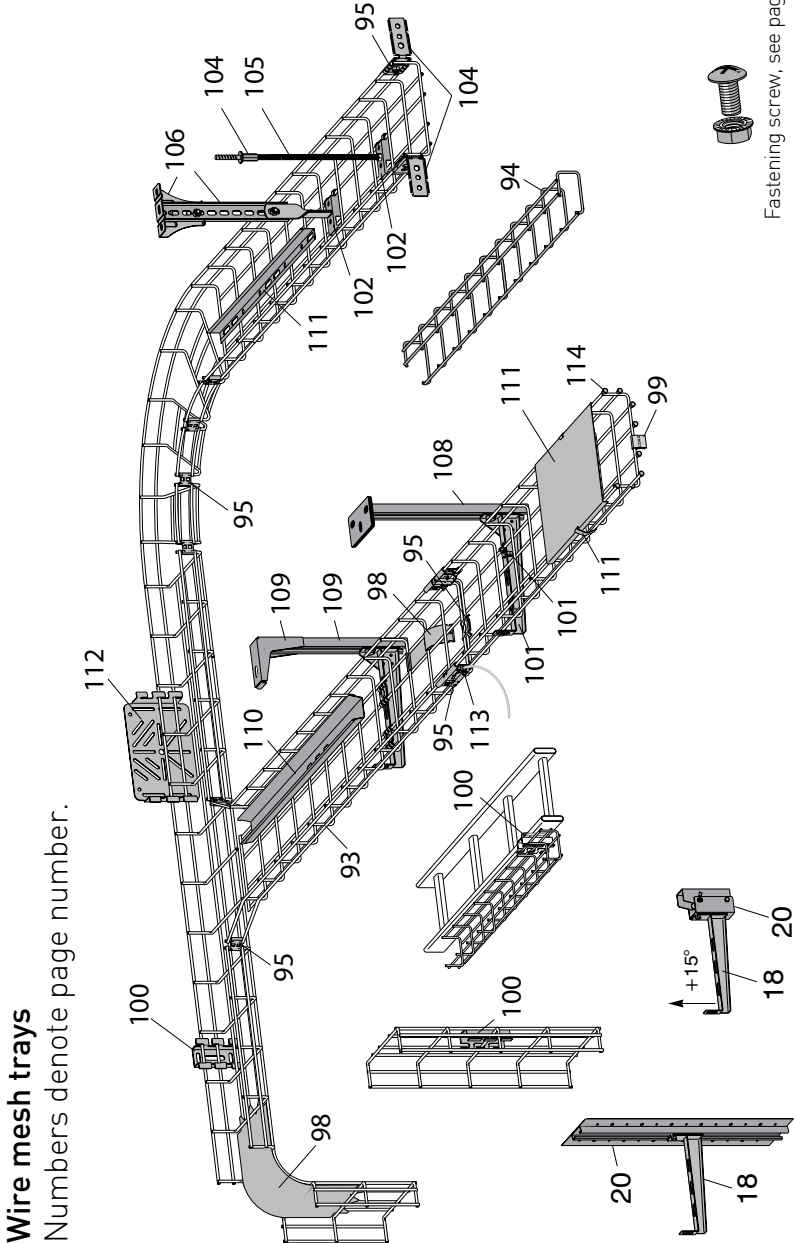

Wire mesh trays
Numbers denote page number.

The letter in the MP No. denotes the surface finish according to: (also refer to page 4).

E = Elzinc 10 µm
S = Zinc 20 µm
Z = Zinc SS-EN ISO1461

A = Aluzinc 20 µm (AZ 150)
AZ = Aluzinc 25 µm (AZ 185)

Wire mesh trays

Wire mesh tray – 2.5 m

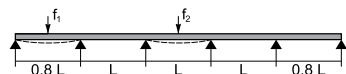
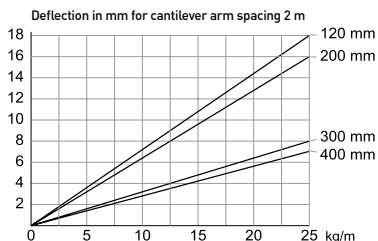
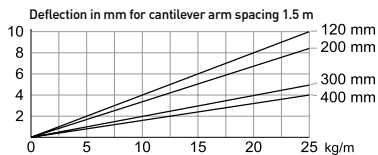

The diagram applies for an inner compartment f2, i.e. all compartments except the two outermost. To get the same deflection in the outer compartment f1, the cantilever arm spacing should be 80 % of an inner compartment.

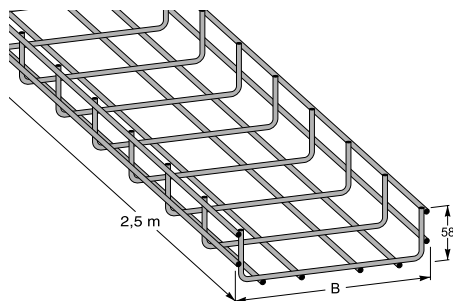

The diagram shows the deflection at $L = 1.5$ m and $L = 2$ m cantilever arm spacing. Ultimate failure load: ≥ 1.7 times the load. The ends of the lateral wires are bevelled.

Wire mesh trays with accessories can be supplied in any colour.

B	Zinc 10 μ m	E-no	Zinc 60 μ m	E-no	Acid resist. E-no	White E-no	Wire- \emptyset
55	MP-719 E	11 163 91	MP-719 Z	11 163 94	MP-719 R	11 163 97	4 mm
75	MP-720 E	11 164 00	MP-720 Z	11 164 03	MP-720 R	11 164 06	4 mm
120	MP-722 E	11 164 09	MP-722 Z	11 164 12	MP-722 R	11 164 15	5 mm
200	MP-723 E	11 164 18	MP-723 Z	11 164 21	MP-723 R	11 164 24	5 mm
300	MP-724 E	11 164 27	MP-724 Z	11 164 30	MP-724 R	11 164 33	5 mm
400	MP-725 E	11 164 36	MP-725 Z	11 164 39	MP-725 R	11 164 42	6 mm
500	MP-726 E	11 164 45	MP-726 Z	11 164 48	MP-726 R	11 164 51	6 mm
600	MP-727 E	11 164 54	MP-727 Z	11 164 57	MP-727 R	11 164 60	6 mm

Wire mesh tray “light” - 3 m

Wire mesh tray “Light” in pre-galvanized wire designed for light loads.

All accessories are designed for wire mesh trays also fit the “light” version. Conform to the requirements for light cable ladders according EL-AMA.

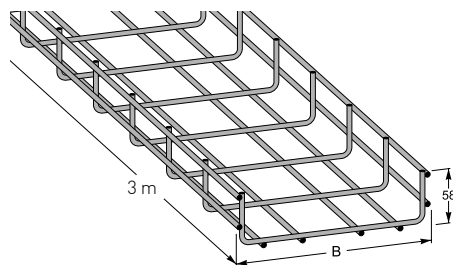

B	Zinc 10 μ m	E-no	Wire- \emptyset
55	MP-719 S3	11 164 63	4 mm
75	MP-720 S3	11 164 65	4 mm
120	MP-722 S3	11 164 67	4 mm
200	MP-723 S3	11 164 69	4 mm

The letter in the MP No. denotes the surface finish according to: **V** = White RAL 9010 **B** = Beige NCS 2502-Y (also refer to page 4).

R = Acid resistant

Wire mesh trays

Wire mesh tray (ceiling) – 2.5 m

For installing directly on the ceiling using universal bracket MP 731 S. Ideal for low ceiling heights and during rebuilding work. Fully open cable routing from the side. In concrete ceilings – use MP-concrete screw – see page 152.

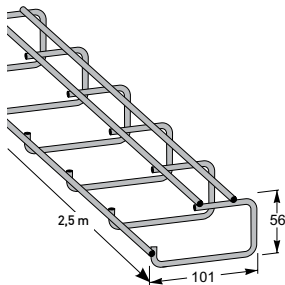

Zinc 10 µm	E-no
MP-729 E	11 164 71

Wire mesh tray flex – 2.5 m

Secured with screws between the two longitudinal wires. Screw size max. Ø 5 mm.

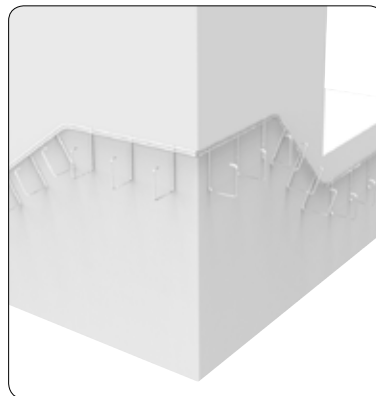
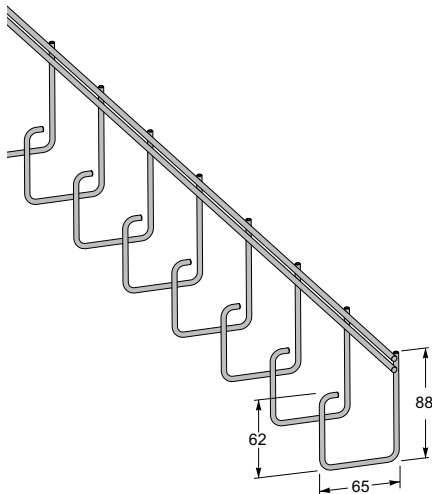

Zinc 10 µm	E-no
MP-728 E	11 164 80

Zinc 60 µm	E-no
MP-728 Z	11 164 81

The letter in the MP No. denotes the surface finish according to: (also refer to page 4).

E = Elzinc 10 µm
S = Zinc 20 µm
Z = Zinc SS-EN ISO1461

A = Aluzinc 20 µm (AZ 150)
AZ = Aluzinc 25 µm (AZ 185)

Coupling piece

Fitted by folding on the side of the tray after when the locking tongues are bent up with pliers. If necessary the splice can be locked using a fastening screw, see page 114.

Universal bracket fitted from below (width 300-600 mm).

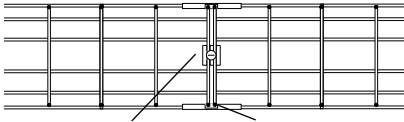

MP-731

MP-730

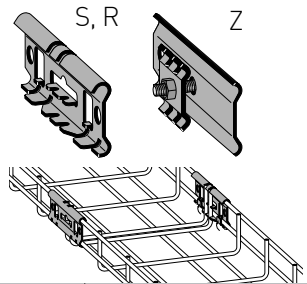

Zinc 20 µm E-no	Zinc 60 µm E-no	Acid resist. E-no	White E-no
MP-730 S 11 165 10	MP-730 Z 11 165 13	MP-730 R 11 165 16	MP-730 V 11 165 12

Corner splice

For producing flat elbows, tee pieces and cross pieces Locked by inserting a screwdriver through one of the holes and bending the tongue between the tray's wires.

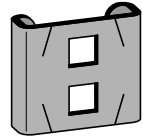
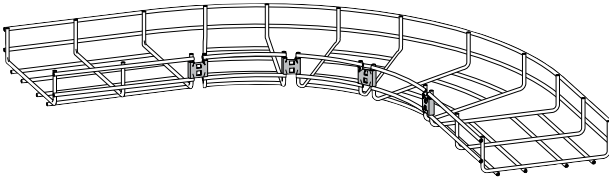

Zinc 20µm E-no	Acid resist. E-no	White E-no
MP-732 S 11 165 20	MP-732 R 11 165 26	MP-732 V 11 165 22

Universal bracket

Designed for universal fastening in the trays and for locking cantilever arm and angle brackets. For widths 300 to 600 mm, use a universal bracket in the bottom of the wire mesh tray to reinforce the joint (see below).

Secured with one fastening screw, see page 114.

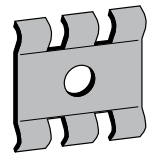
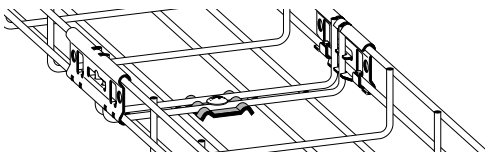

Zinc 20 µm E-no	Zinc 60 µm E-no	Acid resist. E-no	White E-no
MP-731 S 11 165 30	MP-731 Z 11 165 33	MP-731 R 11 165 36	MP-731 V 11 165 32

The letter in the MP No. denotes the surface finish according to:
V = White RAL 9010
B = Beige NCS 2502-Y
R = Acid resistant

Screw free solutions

- bend, snap and fold!

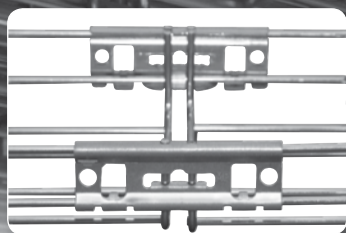

Coupling piece

Fold the splice on the side of the wire mesh tray and **bend** the locking tongues with pliers - finished!



Cantilever arm clips

Secure the cantilever arm against the wire mesh tray with a clip that **snaps** into place - finished!

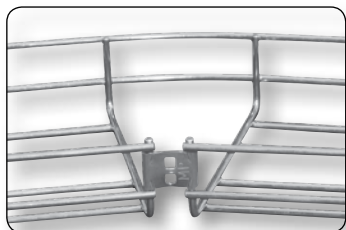

Corner splice

Lock by inserting a screwdriver through one of the holes and **fold** the tongue - finished!



Box 3, 574 21 Vettlanda,
Tel +46 383-76 36 00, fax +46 383-122 50.
www.mpbolagen.

Flat elbow with radius

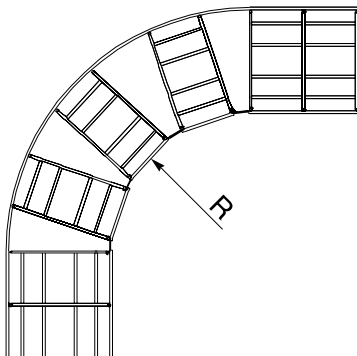

B	Cut compartment	Corner-splice	Radius MP-732
75	1 st	1 st	
120	2 st	2 st	90 mm
200	4 st	4 st	260 mm
300	6 st	6 st	420 mm
400	8 st	8 st	580 mm

Flat elbow with corner

One side edge of the wire mesh tray is cut off after which they are joined.

One universal bracket is fitted from above and the other from below.

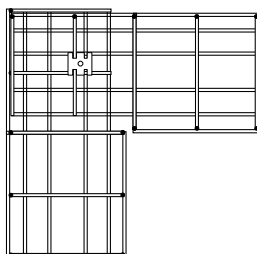

B	Universal bracket MP-731
75	2 pcs
120	2 pcs
200	2 pcs
300	4 pcs
400	4 pcs
500	4 pcs
600	4 pcs

Tee, cross pieces

The side of the primary tray is cut from 100 mm wider than the connecting tray. The connecting tray's sides are cut up and bent outward. Joining is performed using two **corner splices - MP-732** and a **universal bracket MP 731**.

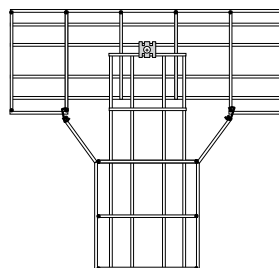

Wire mesh trays

Bending plate

The bending plate is made of aluminium and is used for upward and downward falls with softer types of cables.

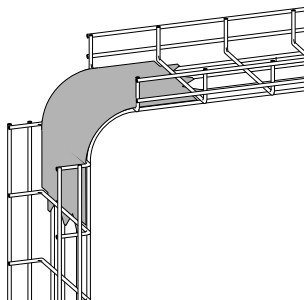
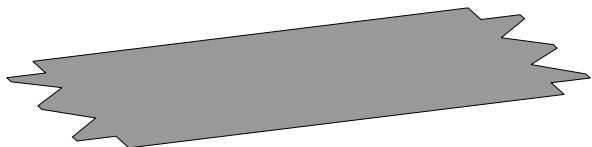

B	Aluminium	E-no
120	MP-782 C	11 165 90
200	MP-783 C	11 165 93
300	MP-784 C	11 165 96
400	MP-785 C	11 165 99

Radius limiter

The radius limiter is used to protect the sensitive cables with downward falls from the wire mesh trays. The radius limiter is made of aluminium and snaps onto the wire mesh trays.

- MP-786 C** fits width 200 mm, without centre compartment.
- MP-787 C** fits width 300 mm, without centre compartment.
- MP-788 C** is suitable for widths of 400, 500 and 600 mm, and for centre compartment 120-600 mm.

(NOTE! Do not fit wire mesh tray "light")

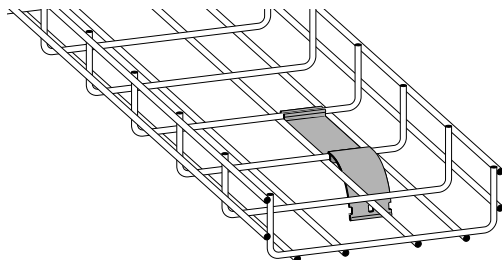
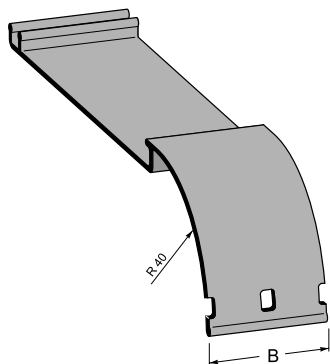

B	Aluminium	E-no
34	MP-786 C	11 167 00
39	MP-787 C	11 167 01
53	MP-788 C	11 167 02

The letter in the MP No. denotes the surface finish according to: (also refer to page 4).

E = Elzinc 10 µm
S = Zinc 20 µm
Z = Zinc SS-EN ISO1461

A = Aluzinc 20 µm (AZ 150)
AZ = Aluzinc 25 µm (AZ 185)

Wire mesh trays

Label holder

Label holder that clips onto the wire mesh tray.

10 per package.



MP-780 CO



MP-780 OP



MP-780 PA



MP-780 PO

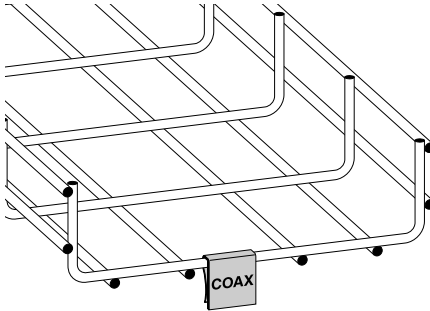

Plastic	E-no
MP-780 CO	11 167 10
MP-780 OP	11 167 11
MP-780 PA	11 167 12
MP-780 PO	11 167 13

Installation tip radius limiter

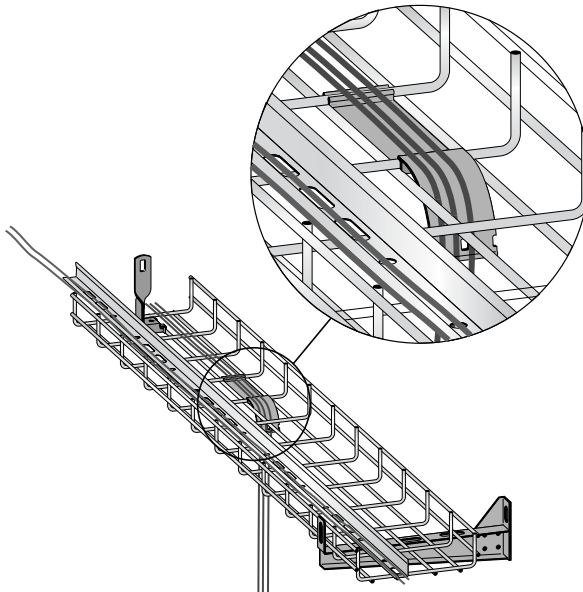

The letter in the MP No. denotes the surface finish according to: [also refer to page 4].

V = White RAL 9010
B = Beige NCS 2502-Y

R = Acid resistant

Wire mesh trays

Wall bracket mini

Wall bracket for suspending wire mesh trays horizontally, vertically, or on end along walls. Primarily designed for widths 55 and 75 mm.

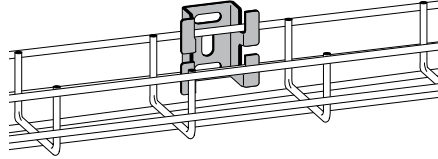
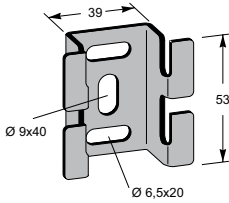

Zinc 20 µm E-no	Zinc 60 µm E-no	Acid resist. E-no	White E-no
MP-734 S 11 165 85	MP-734 Z 11 165 87	MP-734 R 11 165 88	MP-734 V 11 165 86

Wall bracket

Wall bracket for suspending wire mesh trays horizontally, vertically, or on end along walls. Primarily designed for widths 75 and 120 mm.

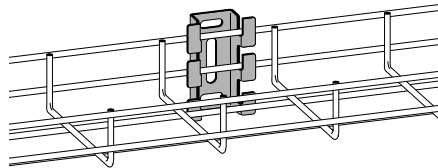
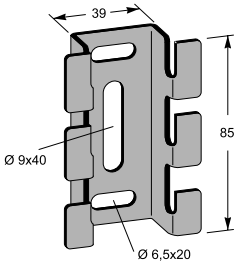

Zinc 20 µm E-no	Zinc 60 µm E-no	Acid resist E-no	White E-no
MP-735 S 11 166 03	MP-735 Z 11 166 06	MP-735 R 11 166 09	MP-735 V 11 166 05

Fastening clamp

The fastening clamp is used together with wall bracket (MP-735) for the suspension of MP-wire mesh trays on extraneous cable ladders.

MP-735 is fastened directly in the side profile when fastening in MP-cable ladders.

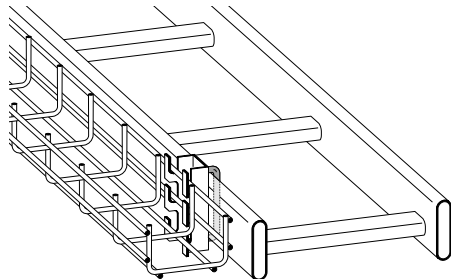
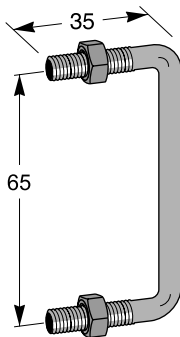

Zinc 10 µm E-no
MP-736 E 11 166 10

100 The letter in the MP No. denotes the surface finish according to: (also refer to page 4).

E = Elzinc 10 µm
S = Zinc 20 µm
Z = Zinc SS-EN ISO1461

A = Aluzinc 20 µm (AZ 150)
AZ = Aluzinc 25 µm (AZ 185)

Wire mesh trays

Cantilever arm type KL

Lock the wire mesh tray on the cantilever arm using bracket clips MP-733, see below.

Maximum load = 150 kg.

Ultimate failure load: ≥ 1.7 times the maximum load.

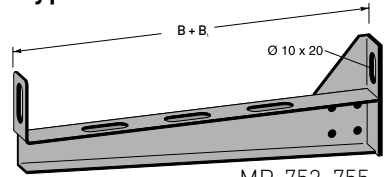
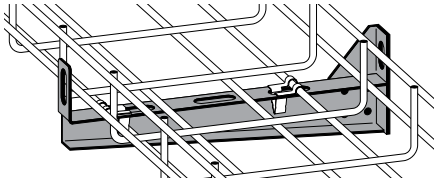

MP-752-755

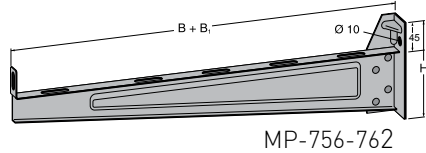

MP-756-762

B	B1	H	Zinc 20 µm	E-no	Zinc 60 µm	E-no	Acid resist.	E-no	White	E-no
120	70	72	MP-752 S	11 165 43	MP-752 Z	11 165 46	MP-752 R	11 165 49	MP-752 V	11 165 44
200	40	80	MP-753 S	11 165 52	MP-753 Z	11 165 55	MP-753 R	11 165 58	MP-753 V	11 165 53
300	40	90	MP-754 S	11 165 61	MP-754 Z	11 165 64	MP-754 R	11 165 67	MP-754 V	11 165 62
400	40	100	MP-755 S	11 165 70	MP-755 Z	11 165 73	MP-755 R	11 165 76	MP-755 V	11 165 71
500	50	150	MP-756 S	11 165 74	MP-756 Z	11 165 78	MP-175 R	11 165 79	MP-756 V	11 165 75
600	50	150	MP-762 S	11 165 80	MP-762 Z	11 165 84	MP-176 R	11 165 81	MP-762 V	11 165 82

Cantilever arm clips

Cantilever arm clips for fastening wire mesh trays on the cantilever arm - type KL.

10 pcs/package.

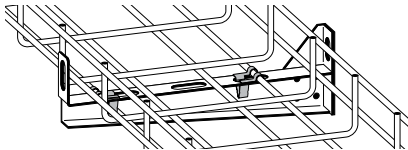

Acid resist.	E-no
MP-733 R	11 165 83

Backing plate

The backing plate is used to improve the distribution of surface pressure on a cantilever arm on walls with a porous surface material or the like.

Plate thickness 5 mm.

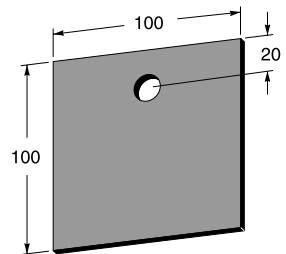
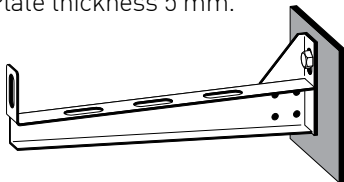

Zinc 60 µm	E-no	Acid resist.	E-no	White	E-no
MP-962 Z	11 172 80	MP-962 R	11 172 82	MP-962 V	11 172 81

The letter in the MP No. denotes the surface finish according to:
V = White RAL 9010
B = Beige NCS 2502-Y
 (also refer to page 4).

R = Acid resistant

Wire mesh trays

Support yoke 55 - 75 mm

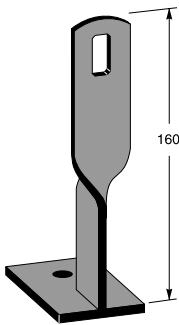

Support yoke designed for 55 and 75 mm wire mesh trays. Wire mesh trays are locked with the help of the universal bracket and fastening screw MP-937 - see page 114.

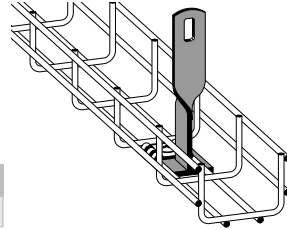

Zinc 10 µm	E-no
MP-766 E	11 166 89

Zinc 60 µm	E-no
MP-766 Z	11 166 90

Support yoke 55 - 75 mm

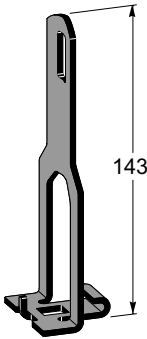

Easily mounted on the pins in the wire mesh tray and secured by bending the catch on the yoke with pliers.

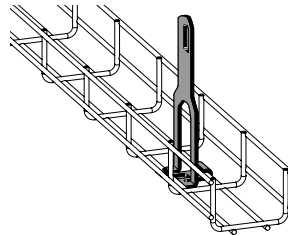

Zinc 60 µm	E-no
MP-769 Z4	11 166 57

Support yoke 120 - 600 mm

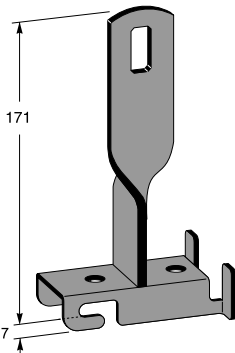

Support yoke for widths 120-600 mm. The widths of 300-600 mm can be supplemented with a support for wire mesh yoke to prevent the edges bend down. Maximum load = 80 kg. Ultimate failure load: ≥ 1.7 times the maximum load.

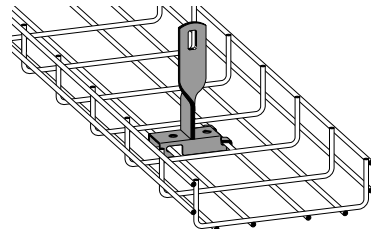

Zinc 10 µm	E-no
MP-757 E	11 166 63

Zinc 60 µm	E-no
MP-757 Z	11 166 67

Acid resist.	E-no
MP-757 R	11 166 65

White	E-no
MP-757 V	11 166 64

Wire mesh trays

Support yoke for threaded rod

Support yoke intended for fastening to M10 threaded rod.
Secured to the threaded rod with two M10 nuts.
Exercise care in the event of unbalanced loads.

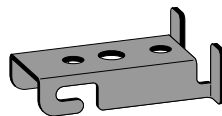
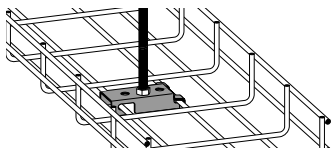

Zinc 10 µm	E-no	Zinc 60 µm	E-no	Acid resist.	E-no	White	E-no
MP-759 E	11 166 77	MP-759 Z	11 166 81	MP-759 R	11 166 79	MP-759 V	11 166 78

Support yoke for threaded rod

Support yoke designed for 55 and 75 mm wire mesh trays.
Wire mesh trays are locked using universal bracket MP-731
- see page 95 and fastening screw MP-937 - see page 114.

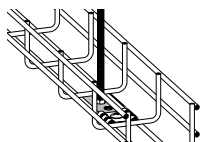

Zinc 20 µm	E-no	Zinc 60 µm	E-no	Acid resist.	E-no	White	E-no
MP-768 S	11 166 92	MP-768 Z	11 166 94	MP-768 R	11 166 95	MP-768 V	11 166 93

Support for wire mesh yoke 300-600 mm

Used together with Support yoke MP-757 for wire mesh trays in the width 300-600 mm, to prevent the wire mesh tray bending with heavy loads. The support is screwed to the support yoke with fastening screw MP-937 **after** the wire mesh tray has been fitted in the support yoke.

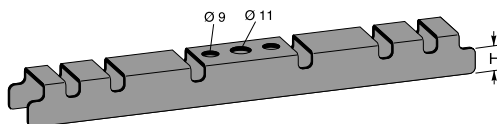
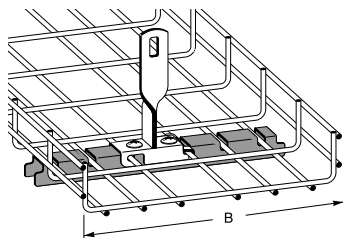

B	H	Zinc 10 µm	E-no	Zinc 60 µm	E-no	Acid resist.	E-no	White	E-no
300-400	14	MP-758 E	11 166 70	MP-758 Z	11 166 74	MP-758 R	11 166 72	MP-758 V	11 166 69
500-600	20	MP-767 E	11 166 71	MP-767 Z	11 166 75	MP-767 R	11 166 73	MP-767 V	11 166 76

The letter in the MP No. denotes the surface finish according to:
V = White RAL 9010
B = Beige NCS 2502-Y
 (also refer to page 4).

R = Acid resistant

Wire mesh trays

Angle bracket

Used as an end bracket against the wall or another ladder. Can also be used as a ceiling bracket (only applies to 55 and 120 mm widths). Fitted using universal bracket MP-731 - see page 95 and fastening screw MP-937 - see page 114.

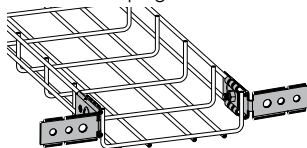
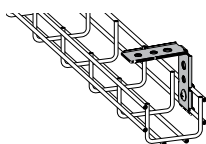
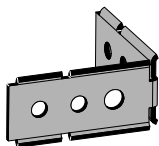

Zinc 20 µm	E-no	White	E-no	Zinc 60 µm	E-no	Acid resist.	E-no
MP-737 S	11 165 38	MP-737 V	11 165 39	MP-737 Z	11 165 40	MP-737 R	11 165 41

Angle bracket

Used as an end bracket against the wall or another ladder. Can also be used as a ceiling bracket (only applies to 75 and 120 mm widths). Fitted using universal bracket MP-731 - see page 95 and fastening screw - see page 114.

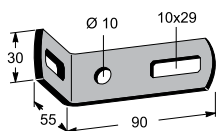

MP-900

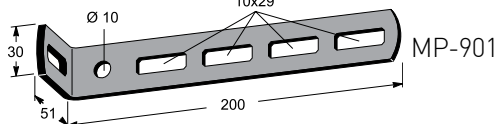

MP-901

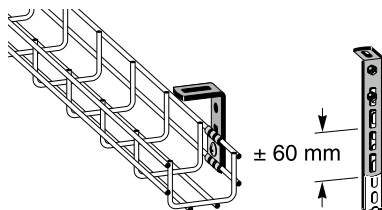

Zinc 10 µm	E-no	Zinc 60 µm	E-no	Acid resist.	E-no	White	E-no
MP-900 E	11 153 84	MP-900 Z	11 153 85	MP-900 R	11 153 87	MP-900 V	11 153 86
		MP-901 Z	11 153 81			MP-901 V	11 153 82

Ceiling bracket for threaded rod M8/M10

Ceiling bracket intended for fastening threaded rod M8 or M10 in concrete. Drill a Ø6x65 mm hole in the substrate, screw the ceiling bracket in the hole. In uncracked concrete K25 the pull-out force is 400 kg with three-fold safety.

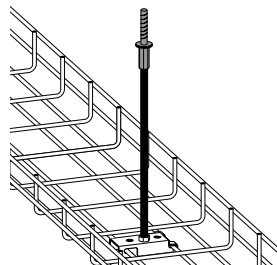

B	Pack.	Zinc 5 µm	E-no
7,5x55	40 st	MP-023 E	11 175 50

The letter in the MP No. denotes the surface finish according to: (also refer to page 4).

E = Elzinc 10 µm
S = Zinc 20 µm
Z = Zinc SS-EN ISO1461

A = Aluzinc 20 µm (AZ 150)
AZ = Aluzinc 25 µm (AZ 185)

Wire mesh trays

Ceiling bracket threaded rod

The ceiling bracket is used to suspend wire mesh trays from the threaded rod. The threaded rod is secured to the ceiling bracket using two nuts MP-044 - see page 103.

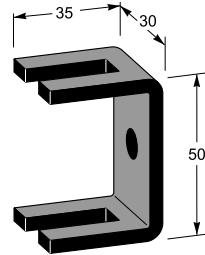
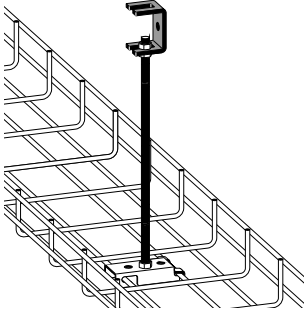

Zinc 10 µm E-no	Zinc 60 µm E-no	Acid resist. E-no
MP-760 E 11 166 84	MP-760 Z 11 166 88	MP-760 R 11 166 86

Nut M10

The nut is used for installing with threaded rods.

50 pcs/package.



Zinc 10 µm E-no	Acid resist. E-no
MP-044 E 11 175 62	MP-044 R 11 175 63

Threaded rod

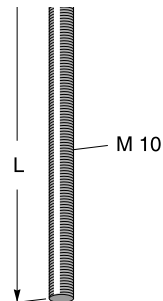
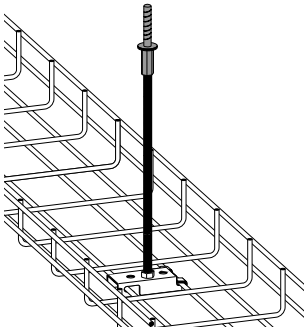

L	Zinc 10 µm E-no	Acid resist. E-no	White E-no
2000	MP-927 E 11 175 55	MP-928 R 11 175 59	MP-927 V 11 175 56
3000	MP-928 E 11 175 57	MP-928 R 11 175 59	MP-928 V 11 175 58

The letter in the MP No. denotes the surface finish according to:
V = White RAL 9010
B = Beige NCS 2502-Y
 (also refer to page 4).

R = Acid resistant

Wire mesh trays

Ceiling bracket type TL

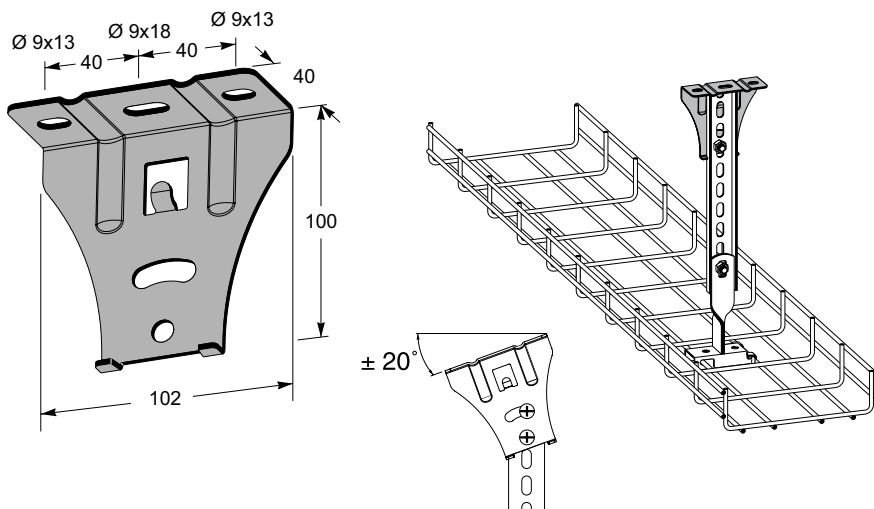

Zinc 20 µm	E-no	Zinc 60 µm	E-no	Acid resist.	E-no	White	E-no
MP-904 S	11 153 46	MP-904 Z	11 153 47	MP-904 R	11 153 49	MP-904 V	11 153 48

Pendant rail

The rail is equipped with cutting marks every 100 mm.

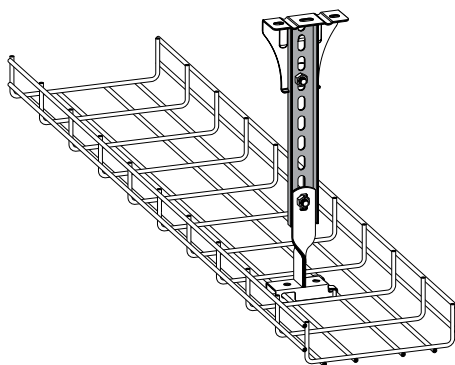
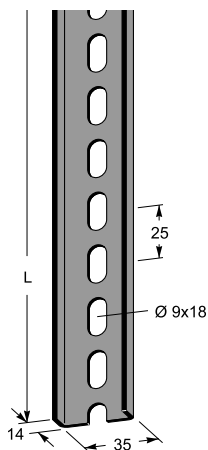

L	Zinc 20 µm	E-no	Zinc 60 µm	E-no	Acid resist.	E-no	White	E-no
2000					MP-910 R	11 153 41		
3000	MP-910 S	11 153 38	MP-910 Z	11 153 39			MP-910 V	11 153 40

The letter in the MP No. denotes the surface finish according to: (also refer to page 4).

E = Elzinc 10 µm
S = Zinc 20 µm
Z = Zinc SS-EN ISO1461

A = Aluzinc 20 µm (AZ 150)
AZ = Aluzinc 25 µm (AZ 185)

Wire mesh trays

Ceiling pendant type MP-P

Hole module cc 25 mm. For acid-resistant installation use pendant rail and ceiling brackets.

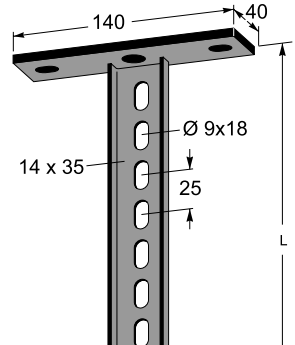
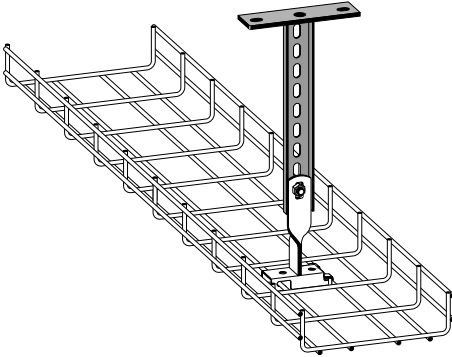

L	Zinc 60 µm	E-no
300	MP-957 Z	11 157 04
400	MP-958 Z	11 157 06
500	MP-959 Z	11 157 08
700	MP-960 Z	11 157 10
1000	MP-961 Z	11 157 12

Pendant bracket

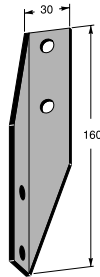
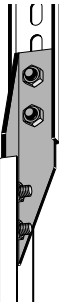

Zinc 60 µm	E-no	White	E-no
MP-918 Z	11 153 23	MP-918 V	11 153 24

Splice for pendant rail

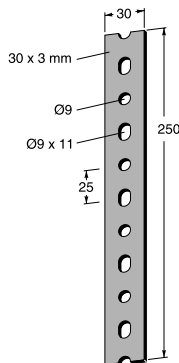
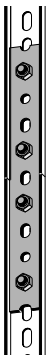

Zinc 60 µm	E-no	White	E-no
MP-919 Z	11 153 11	MP-919 V	11 153 12

The letter in the MP No. denotes the surface finish according to:
V = White RAL 9010
B = Beige NCS 2502-Y
 (also refer to page 4).

R = Acid resistant

Wire mesh trays

Ceiling/floor pendant type MP-V

Ceiling pendant deflection MP-V (for fastening in the pendant – see page 46).

In order to calculate the deflection of the ceiling pendant, the bending moment is calculated according to the formula $M_2 = F \times (B+0.12)/2$. Read the deflection in the diagram for the selected pendant. In the diagram, the maximum permitted deflection according to SS-EN 61537 (1/20 of the length) for each pendant for the end of the load curve.

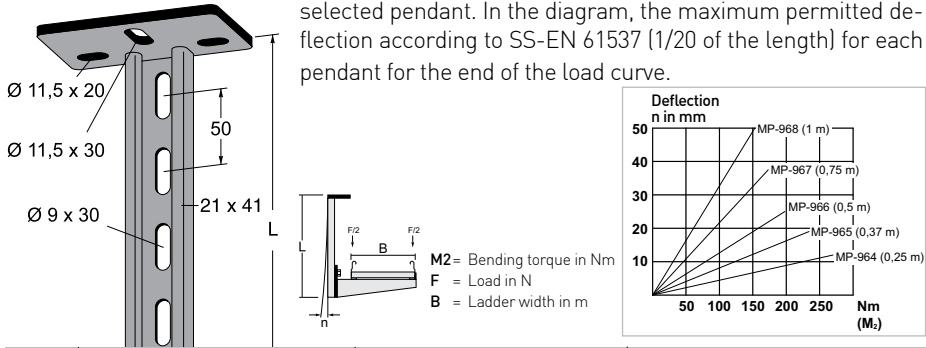

L	Zinc 60 µm	E-no	Acid resist.	E-no	White	E-no
250	MP-964 Z	11 157 20	MP-964 R	11 157 22	MP-964 V	11 157 21
375	MP-965 Z	11 157 24	MP-965 R	11 157 26	MP-965 V	11 157 25
500	MP-966 Z	11 157 28	MP-966 R	11 157 30	MP-966 V	11 157 29
750	MP-967 Z	11 157 32	MP-967 R	11 157 34	MP-967 V	11 157 33
1000	MP-968 Z	11 157 36	MP-968 R	11 157 38	MP-968 V	11 157 37

Ceiling/floor pendant type MP-DV

Ceiling pendant deflection MP-DV (for fastening in the pendant – see page 46).

In order to calculate the deflection of the ceiling pendant, the bending moment is calculated according to the formula $M_2 = F \times (B+0.14)/2$. Read the deflection in the diagram for the selected pendant. In the diagram, the maximum permitted deflection according to SS-EN 61537 (1/20 of the length) or each pendant for the end of the load curve.

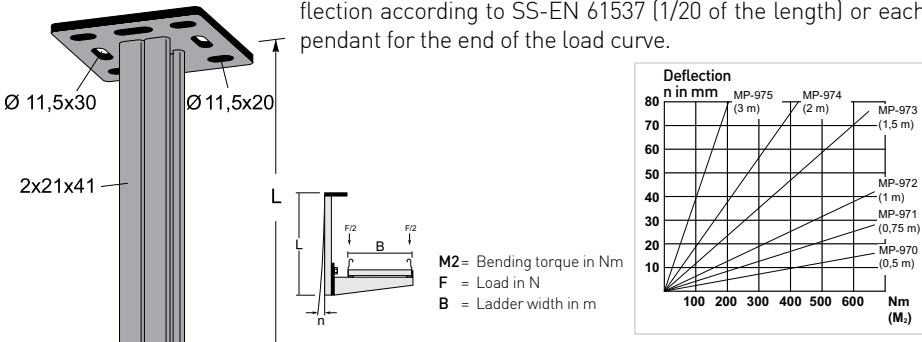

L	Zinc 60 µm	E-no	Acid resist.	E-no	White	E-no
500	MP-970 Z	11 157 40	MP-970 R	11 157 42	MP-970 V	11 157 41
750	MP-971 Z	11 157 44	MP-971 R	11 157 46	MP-971 V	11 157 45
1000	MP-972 Z	11 157 48	MP-972 R	11 157 50	MP-972 V	11 157 49
1500	MP-973 Z	11 157 52	MP-973 R	11 157 54	MP-973 V	11 157 53
2000	MP-974 Z	11 157 56	MP-974 R	11 157 58	MP-974 V	11 157 57
3000	MP-975 Z	11 157 60	MP-975 R	11 157 62	MP-975 V	11 157 61

108 The letter in the MP No. denotes the surface finish according to: (also refer to page 4).

E = Elzinc 10 µm
S = Zinc 20 µm
Z = Zinc SS-EN ISO1461

A = Aluzinc 20 µm (AZ 150)
AZ = Aluzinc 25 µm (AZ 185)

Ceiling bracket

The ceiling bracket is combined with an anchor rail for side-hung ladder installation. Choose from ready-cut lengths or cut to the desired length yourself, see below. NOTE The installation can handle larger loads than the corresponding ceiling pendant type MP-V - see page 108.

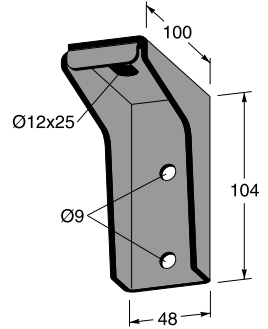
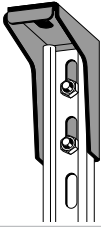

Zinc 20 µm	E-no	Zinc 60 µm	E-no	White	E-no
MP-230 S	11 157 97	MP-230 Z	11 157 98	MP-230 V	11 157 96

Anchor rail type MP-V 21x41 mm

For fastening in rails – see page 46.

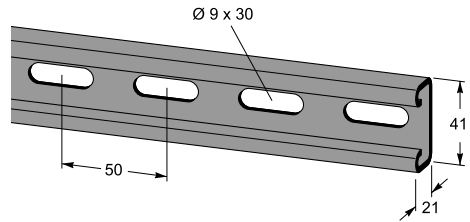
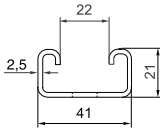

L	Zinc 20 µm	E-no	Zinc 60 µm	E-no	White	E-no
250	MP-024 S	11 158 39	MP-024 Z	11 158 40	MP-024 V	11 158 38
375	MP-025 S	11 158 43	MP-025 Z	11 158 44	MP-025 V	11 158 42
500	MP-026 S	11 158 47	MP-026 Z	11 158 48	MP-026 V	11 158 46
750	MP-027 S	11 158 51	MP-027 Z	11 158 52	MP-027 V	11 158 50
1000	MP-028 S	11 158 55	MP-028 Z	11 158 56	MP-028 V	11 158 54
3000	MP-231 S	11 158 02	MP-231 Z	11 158 00	MP-231 V	11 158 01

T-screw

T-screw for fastening in ceiling pendants/anchor rails. Suitable for profiles with 21 mm and 41 mm. height.

1. Placed in the rail opening.
2. Press the screw.
3. The T screw rotates to the right position.

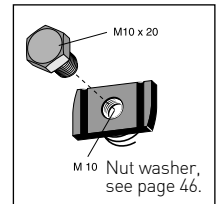
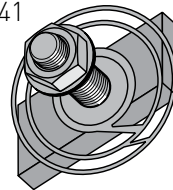
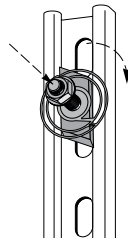

Size	Zinc 10 µm	E-no
M8x25	MP-983 E	11 158 20
M10x35	MP-984 E	11 158 22

The letter in the MP No. denotes the surface finish according to:
V = White RAL 9010
B = Beige NCS 2502-Y
 (also refer to page 4).

R = Acid resistant

Wire mesh trays

Telecom channel unperforated

The channel is designed with fastening holes at the ends and in the middle.

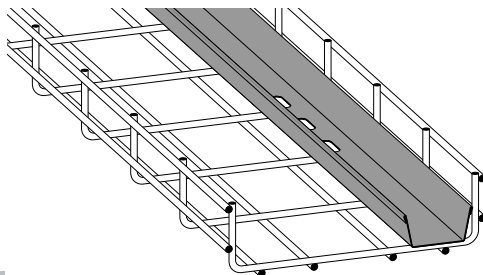
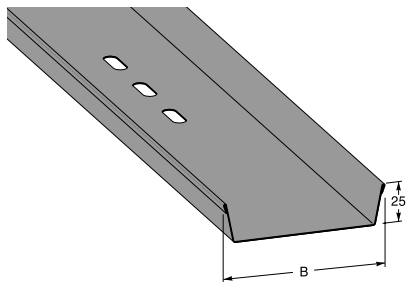

L	B	Zinc 20 µm	E-no
3000	50	MP-128 S	11 156 00
3000	100	MP-129 S	11 156 04
3000	200	MP-130 S	11 156 08

Telecom channel perforated

The large holes can be fitted with Ø 23 mm rubber sleeves to prevent damage to the cord. Found in list 14.

NB: The length of acid resistant telecom channel is 2 m.m.

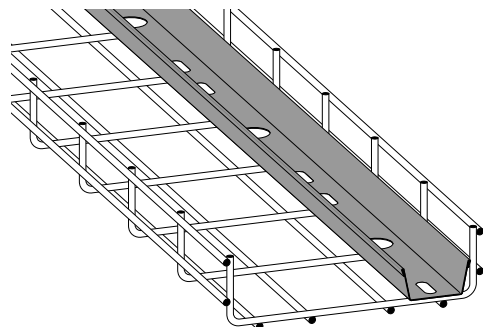
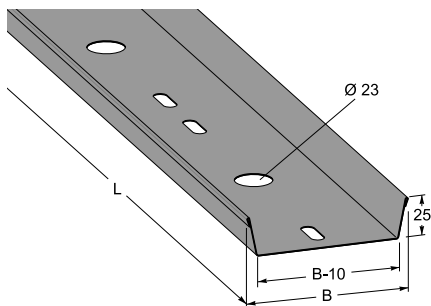

L	B	Zinc 20 µm	E-no	AZ 185	E-no	Acid resist. E-no (L=2m)
3000	50	MP-138 S	11 156 12	MP-138 AZ	11 156 11	MP-138 R 11 156 14
3000	100	MP-139 S	11 156 16	MP-139 AZ	11 156 17	
3000	200	MP-140 S	11 156 20			

The letter in the MP No. denotes the surface finish according to: (also refer to page 4).

E = Elzinc 10 µm
S = Zinc 20 µm
Z = Zinc SS-EN ISO1461

A = Aluzinc 20 µm (AZ 150)
AZ = Aluzinc 25 µm (AZ 185)

Wire mesh trays

Divider

Dividers are secured with folding tongues on the ladder and are joined by overlapping.

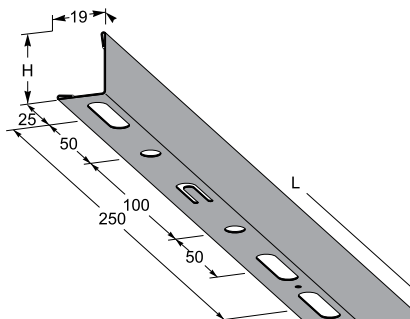
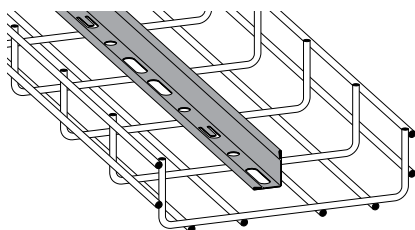

H	L	Zinc 20 µm	E-no	AZ 185	E-no	White	E-no
25	2750	MP-137 S	11 184 72	MP-137 AZ	11 184 74	MP-137 V	11 184 75
40	2750	MP-149 S	11 184 78	MP-149 AZ	11 184 79		

Cover

The covers are locked with clips, see below.

The length of the acid resistant cover is 1.25 m.

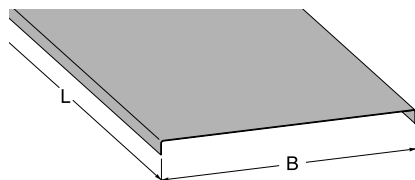
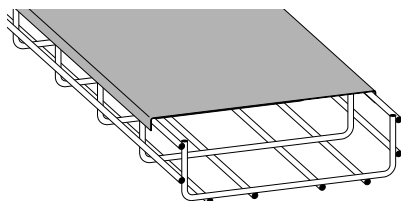

B	Thickn.	Zinc 20 µm	E-no	L	Acid resist.	E-no	L
55	0,6	MP-405 S	11 171 57	3 m	MP-405 R	11 171 58	1,25 m
75	0,6	MP-410 S	11 171 61	3 m	MP-410 R	11 171 63	1,25 m
120	0,6	MP-421 S	11 171 72	3 m	MP-421 R	11 171 73	1,25 m
200	0,6	MP-440 S	11 171 79	3 m	MP-440 R	11 171 81	1,25 m
300	0,6	MP-450 S	11 171 97	2 m	MP-450 R	11 171 85	1,25 m
400	1,0	MP-460 S	11 172 00	2 m	MP-460 R	11 171 89	1,25 m
500	1,0	MP-470 S	11 172 03	2 m	MP-470 R	11 172 02	1,25 m
600	1,0	MP-480 S	11 171 95	2 m	MP-480 R	11 171 94	1,25 m

Lock clips

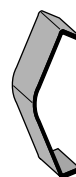
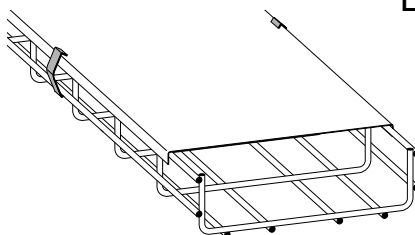

Acid resist.	E-no
MP-748 R	11 166 60

The letter in the MP No. denotes the surface finish according to:

V = White RAL 9010
B = Beige NCS 2502-Y

[also refer to page 4].

R = Acid resistant

Wire mesh trays

Mounting plate

Mounting plate for fitting boxes and socket outlets, etc.

Available with or without hole pattern.

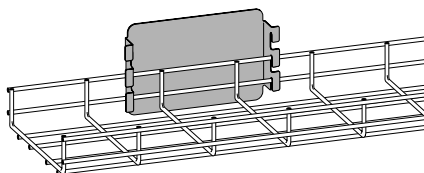
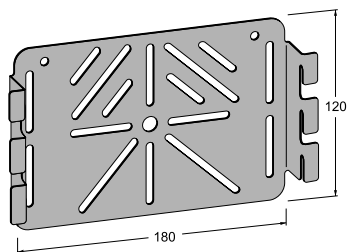

	Zinc 20µm E-no	Zinc 60µm E-no	Acid resist. E-no	White E-no
Perf.	MP-739 S 11 166 18	MP-739 Z 11 166 22	MP-739 R 11 166 20	MP-739 V 11 166 19
Unperf.	MP-738 S 11 166 12	MP-738 Z 11 166 16	MP-738 R 11 166 14	MP-738 V 11 166 13

Mounting plate + socket outlet IP21

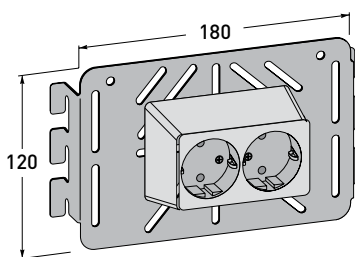

Mounting plate with pre-installed 2-way socket outlet IP21 in white halogen-free polycarbonate, tamper resistant with base plate. Two neutral through wiring clamps, screw terminals.

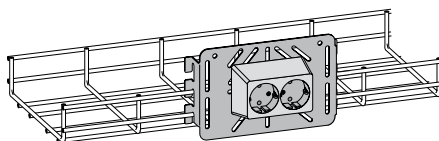

Zinc 20 µm E-no
MP-739 SF 11 166 24

Mounting plate + socket outlet IP55

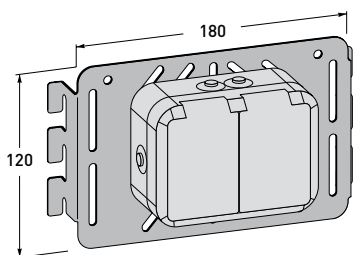

Mounting plate with pre-installed 2-way enclosed socket outlet IP55 in white halogen-free polycarbonate, tamper resistant. Two neutral through wiring clamps.

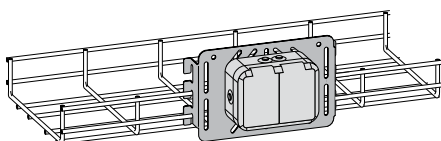

Zinc 20 µm E-no
MP-739 SG 11 166 25

Wire mesh trays

Mounting plate + junction box IP65

Mounting plate with pre-installed junction box IP65 in white halogen-free plastic with ten entries.

Supplied without terminal block.

Suitable strain relief - ABB E14 384 04.

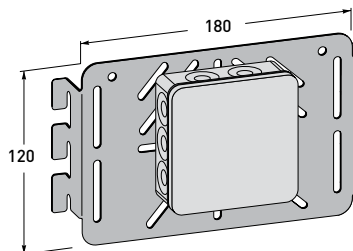
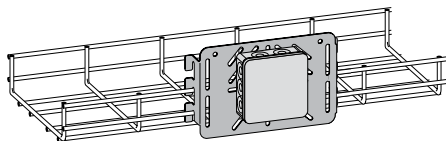

Zinc 20 µm E-no
MP-739 SD 11 166 23

Mesh trays

Potential connection screw

Using the potential connection screw you can connect the conductor directly without a cable lug.

10 pcs/package.

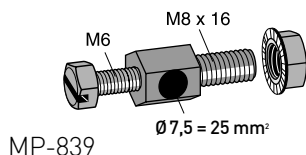
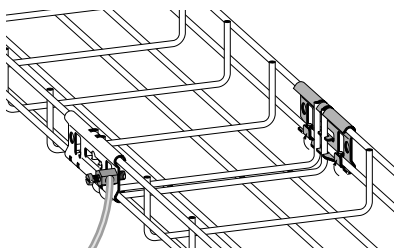

MP-839

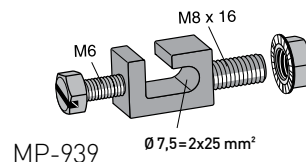

MP-939

Zinc 10 µm	E-no	Acid resist.	E-no
MP-839 E	11 157 88	MP-839 R	11 157 89
MP-939 E	11 157 83	MP-939 R	11 157 85

Cutters

Manual bolt cutters with side cutter.

Designed for cutting wire mesh trays.

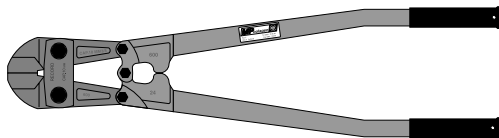

Cutters E-no
MP-790 P 16 239 88

The letter in the MP No. denotes the surface finish according to:
V = White RAL 9010
B = Beige NCS 2502-Y
 (also refer to page 4).

R = Acid resistant

Wire mesh trays

Plastic cap

Fitted as protection on the ends of protruding wires. Made of flame retardant material.

100 pcs/package.

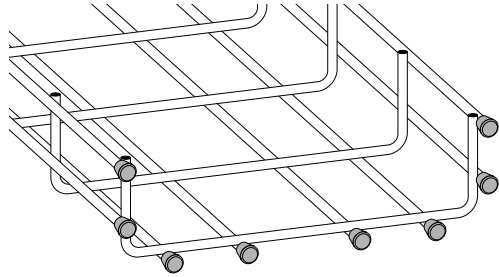

Ø	Fits ladder width	Plastic	E-no
4	55-75 mm (incl. light ladder)	MP-761 P	11 167 03
5	120-300 mm	MP-763 P	11 167 06
6	400-600 mm	MP-765 P	11 167 09

Fastening screw

The fastening screws are **NOT** supplied with accessories.

50 pcs/package.

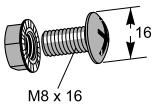

M8 x 16

MP-937

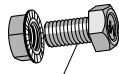

M8 x 16

MP-295

Zinc 10 µm	E-no	Zinc 60 µm	E-no	Acid resist.	E-no
MP-937 E	11 157 11	MP-937 Z	11 156 80	MP-295 R	11 157 80

114 The letter in the MP No. denotes the surface finish according to: (also refer to page 4).

E = Elzinc 10 µm
S = Zinc 20 µm
Z = Zinc SS-EN ISO1461

A = Aluzinc 20 µm (AZ 150)
AZ = Aluzinc 25 µm (AZ 185)