

Manufacturer

GROMTOR Sp. z o.o.

Ul. Iwaszkiewicza 22/5, 52-211 Wrocław

NIP: 8992853476 REGON: 381817326

tel: +48 733 788 655 e-mail: info@gromtor.pl

DATA SHEET

Mast holder for $\varnothing 40$ interception mast GROMTOR

Product code:

510312

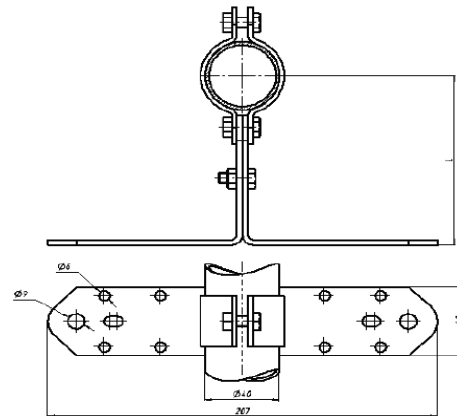

Description	Dimension	Material	Code
Mast holder - For $\varnothing 40$ mast	L - 100mm	FeZn	510312

In accordance with standard: PN- 62561

Corresponds to the requirements of standard: PN-EN 62305

Used for lightning protection systems for assembling masts to the wall or steel constructions

5 years warranty.

